

◆ PRECISION INSTRUMENTS FOR TEST AND MEASUREMENT ◆

HATS-Y SERIES
High Accuracy Resistance
Transfer Standards

User and Service Manual



Copyright © 2011 IET Labs, Inc.

Effectivity: Serial numbers beginning with E.
HATSYim/April, 2011



IET LABS, INC.

534 Main Street, Westbury, NY 11590

www.ietlabs.com

TEL: (516) 334-5959 • (800) 899-8438 • FAX: (516) 334-5988

◆ PRECISION INSTRUMENTS FOR TEST AND MEASUREMENT ◆



IET LABS, INC.

534 Main Street, Westbury, NY 11590

www.ietlabs.com

TEL: (516) 334-5959 • (800) 899-8438 • FAX: (516) 334-5988

WARRANTY

We warrant that this product is free from defects in material and workmanship and, when properly used, will perform in accordance with applicable IET specifications. If within one year after original shipment, it is found not to meet this standard, it will be repaired or, at the option of IET, replaced at no charge when returned to IET. Changes in this product not approved by IET or application of voltages or currents greater than those allowed by the specifications shall void this warranty. IET shall not be liable for any indirect, special, or consequential damages, even if notice has been given to the possibility of such damages.

THIS WARRANTY IS IN LIEU OF ALL OTHER WARRANTIES, EXPRESSED OR IMPLIED, INCLUDING BUT NOT LIMITED TO, ANY IMPLIED WARRANTY OF MERCHANTABILITY OR FITNESS FOR ANY PARTICULAR PURPOSE.

Contents

WARRANTY	iii
Contents	iv
Figures	v
WARNING	vi
CAUTION	vi
Chapter 1	
INTRODUCTION	1
1.1 General Description	1
Chapter 2	
SPECIFICATIONS	2
Chapter 3	4
INSTALLATION	4
3.1 Initial Inspection	4
3.2 Installation	4
3.3 Repackaging for Shipment	4
3.4 Storage	4
Chapter 4	
OPERATION	5
4.1 Initial Inspection and Setup	5
4.2 Use as a Stand-Alone Standard	6
4.3 Use as a Precision Voltage Divider	6
4.4 General Considerations for best performance	6
Chapter 5	
MAINTENANCE	9
5.1 Verification of Performance	9
5.1.1 Calibration Interval)	9
5.1.2 General Considerations	9
5.1.3 Verification Procedure	9
5.2 Calibration	9

Figures

Figure 2.1. Typical OPERATING GUIDE Affixed to Unit	3
Figure 2.2. Typical Calibration Chart, providing deviations, Affixed to Unit	3
Figure 4.1a. 10 resistors in series: Resistance= 10R	7
Figure 4.1b. 10 resistors in parallel: Resistance= R/10	7
Figure 4.1c. 3 groups of 3, series-parallel: Resistance= 1 R	7
Figure 4.1d. 5 groups of 2, series-parallel: Resistance= 0.4 R	7
Figure 4.1 HATS-Y Resistance Combinations	7
Figure 4.2 Calibration Chart Affixed to unit	8
Figure 4.3 HATS-Y configured as a Precision Voltage divider 50% Ratio in this example	8



WARNING



OBSERVE ALL SAFETY RULES
WHEN WORKING WITH HIGH VOLTAGES OR LINE VOLTAGES.

**Dangerous voltages may be present inside this instrument. Do not open the case
Refer servicing to qualified personnel**

HIGH VOLTAGES MAY BE PRESENT AT THE TERMINALS OF THIS INSTRUMENT

WHENEVER HAZARDOUS VOLTAGES (> 45 V) ARE USED, TAKE ALL MEASURES TO
AVOID ACCIDENTAL CONTACT WITH ANY LIVE COMPONENTS.

USE MAXIMUM INSULATION AND MINIMIZE THE USE OF BARE
CONDUCTORS WHEN USING THIS INSTRUMENT.

Use extreme caution when working with bare conductors or bus bars.

WHEN WORKING WITH HIGH VOLTAGES, POST WARNING SIGNS AND
KEEP UNREQUIRED PERSONNEL SAFELY AWAY.



CAUTION



DO NOT APPLY ANY VOLTAGES OR CURRENTS TO THE TERMINALS OF THIS
INSTRUMENT IN EXCESS OF THE MAXIMUM LIMITS INDICATED ON
THE FRONT PANEL OR THE OPERATING GUIDE LABEL.

Chapter 1

INTRODUCTION

1.1 General Description

The **HATS-Y** Series (Figure 1.1) is a family of transfer standards suitable for making resistance calibration transfer measurements from 10 k Ω to 1 G Ω , with step sizes ranging from 100 k Ω to 100 M Ω

In order to perform calibrations with a high degree of accuracy, reference standards must normally be employed at every range or decade of the measuring or calibration instrumentation. Clearly this can be difficult and costly, since these standards must be highly stable and their values must be known with a high degree of certainty and with a sufficient resolution. To minimize the cost and difficulty, a more practical means of performing such calibrations is to use transfer standards.

The **HATS-Y** Series of transfer standard consists of 11 matched equal value resistors, R, which may be connected in series or parallel combinations to produce a number of values such as R/10, R, and 10R, thereby allowing progressive transfers to higher or lower decades. For lower resistance values (below 10 k Ω) The **HATS-LR** Series of transfer standards may be used.

If one has a single primary standard with a traceable calibration, one can calibrate the transfer standard to the primary standard. The transfer standard may then be used at R/10, R, and at 10R, where R is the step size. It may be used at these *three* decades with an uncertainty that is equal to the initial calibration uncertainty of the steps plus the transfer uncertainty. For example, if a 100 k Ω step HATS-Y unit has a nominal uncertainty of 5 ppm and a transfer uncertainty of 2 ppm, then it may be used at 10 k Ω and 1 M Ω with an uncertainty of 7 ppm. The nominal adjustment error (the difference between actual value

and nominal) for all three decades is essentially the same, e.g. if the adjustment error at 100 k Ω is 4 ppm, then it is also 4 ppm at 10 k Ω and 1 M Ω , remembering that the transfer accuracy error has to be added at these additional decade settings.

The **HATS-Y** standards are constructed using matched low temperature coefficient, hermetically sealed resistors (except for 10 and 100 M Ω step units) for high stability and imperviousness to moisture. Each resistance step is composed of multiple individual resistors for better power handling, heat distribution, and higher voltage capability. In addition, there is a trimming network that allows precise setting of the resistance step values, and greatly simplifies subsequent calibrations.

The switches are of special low-leakage construction. Switches are placed at every junction and at the two ends of the series string to connect that junction to either of the two binding posts; a center-off setting provides for no connection to that junction. By means of these switches, the resistances may be connected in various series-parallel combinations.

Low-thermal-emf five way binding posts are used for connections to the two buses, and a shielded bnc connector provides for connection to one end of the resistor string. A third, metal, binding post provides a connection to the metal case; this may be used as a guard.

The unit is housed in a contamination-and-moisture-resistant case. The insulation materials in the instrument are Kel-F plastic and teflon, for the highest possible resistance and low moisture absorption.

Chapter 2 SPECIFICATIONS

For convenience to the user, the pertinent specifications are given in an **OPERATING GUIDE**, Figure 2.1, affixed to the unit.

A calibration chart, as shown in Figure 2.2, is also affixed to the side of the unit. This gives the individual and progressive cumulative deviations from nominal. These are deviations which may be used for transfers.

Specifications:

Step Size	100 k	1 M	10 M	100 M
Adjustment Accuracy	±10 ppm	±20 ppm	±20 ppm	±100 ppm
Transfer Accuracy	±2 ppm	±2 ppm	±2 ppm	±30 ppm
Stability ppm/year	±10 ppm	±15 ppm	±20 ppm	±30 ppm
Stability long term	±30 ppm	±30 ppm	±30 ppm	±50 ppm
Temperature Coefficient	±1 ppm/°C	±3 ppm/°C	±5 ppm/°C	±5 ppm/°C
Matching				
Adj. Acc.	±10 ppm	±10 ppm	±10 ppm	±20 ppm
TC	±1 ppm	±3 ppm	±3 ppm	±5 ppm
Calibration Uncertainty	±5 ppm	±10 ppm	±10 ppm	±15 ppm

Calibration Conditions: 23°C, with meter guard applied to COM and ground applied to the center metal post, at low power, traceable to SI. Initial calibration data is supplied with each instrument.

Leakage Resistance: >10 TΩ from terminal to case.

Power Coefficient: <±0.05 ppm/mW per resistor.

Maximum Applied Input: 2500 V, or 1 W per resistor, or 10 W for entire unit, whichever applies first. 3500 V peak between any terminal and case.

Resistor Type: Matched low temperature coefficient, hermetically sealed resistors, or high voltage film resistors for 10 M and 100 MΩ steps. In addition, there is a lockable trimming potentiometer that allows precise setting of the resistance step values, and greatly simplifies subsequent calibrations.

Switches: The switches are of special low-leakage construction. The switches are tied to every junction and at the two ends of the series string to connect that junction to either of the two binding posts; a center-off setting provides for no connection to that junction. By means of these switches, the resistances may be connected in various series-parallel combinations

Terminals: Two low-thermal-emf five way binding posts; a shielded bnc connector provides for connection to one end of the resistor string. A third metal binding post provides for connection to the metal case; this may be used as a guard.

Dimensions: 35.6 cm W x 16.5 cm H x 10.2 cm D (14" x 6.5" x 4").

Weight: 5 kg (11 lb.).

Functional Schematic:

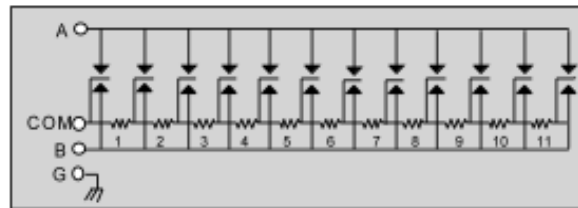

HATS-Y OPERATING GUIDE

Transfer Accuracy: Limited only by short term repeatability of resistance values.

Calibration Conditions: 23°C, with meter guard applied to COM and ground applied to G, at low power, traceable to SI. Calibration data supplied with instrument.

Power Coefficient: ± 0.05 ppm/mW per resistor.

Maximum Applied Input: 2500 V, or 1 W per resistor, or 5 W for entire unit, whichever limit applies first. 3500 V peak, between any terminal and case.

Leakage Resistance: > 10 T Ω from terminal to case.

Operation: (With switch 0 being leftmost). To set standard to R/10, set Switch 0 down, Switch 1 up, switch 2 down and so on; Switch 11 off.

To set standard to 10R, set Switch 0 down, Switch 10 up, all other switches off.

To set standard to 1R, set Switches 0 and 6 down, Switches 3 and 9 up, all other switches off.

Functional Schematic:

MODEL: HATS-Y-100M SN: E1-0536109

NET LABS, INC. Westbury, NY 11590
(516) 334-5959 • (800) 899-8438

HATS-Y10M (PPMS99)/4-406

Figure 2.1. Typical OPERATING GUIDE Affixed to Unit

CALIBRATION CHART

Deviations from
10 M Ω Nominal

	Individual (ppm)	Cumulative (ppm)	Temperature: 23.1°C
R1	3.8	3.8	Date: 29 Mar 2006
R2	5.5	4.6	
R3	1.1	2.4	Date Due: 29 Mar 2007
R4	0.9	2.0	
R5	0.6	1.7	Model: HATS-Y-10M
R6	2.7	1.9	
R7	0.2	1.6	Serial Number: E1-0536108
R8	4.6	2.0	
R9	0.7	1.9	BY: JOS
R10	2.5	1.9	
R11	6.5	2.3	Traceable to SI

NET LABS, INC. Westbury, NY 11590
• 516-334-5959 • (FAX) 516-334-5988
www.netlabs.com

Figure 2.2. Typical Calibration Chart, providing deviations, Affixed to Unit

Chapter 3 INSTALLATION

3.1 Initial Inspection

IET instruments receive a careful mechanical and electrical inspection before shipment. Upon receipt, verify that the contents are intact and as ordered. The instrument should then be given a visual and operational inspection.

If any shipping damage is found, contact the carrier and IET Labs. If any operational problems are encountered, contact IET Labs and refer to the warranty at the beginning of this manual.

Save all original packing material for convenience in case shipping of the instrument should become necessary.

3.2 Installation

For a rack mounted model, installation on a 19 inch rack may be made using the slots in the rack mounting ears. A mounting location that does not expose the unit to excessive heat is recommended.

For bench models, no installation as such is required, because this instrument series is not powered. Since it is a high-accuracy instrument, it is recommended that a bench space be provided that would not expose it to abuse and keep it protected from temperature extremes and contaminants.

3.3 Repackaging for Shipment

If the instrument is to be returned to IET Labs, contact the Service Department at the number or address, shown on the front cover of this manual, to

obtain a "Returned Material Authorization" (RMA) number and any special shipping instructions or assistance. Proceed as follows:

1. Attach a tag to the instrument identifying the owner and indicate the service or repair to be accomplished. Include the model number, the full serial number of the instrument, the RMA number, and shipping address.
2. Wrap the instrument in heavy paper or plastic.
3. Protect the front panel and any other protrusions with cardboard or foam padding.
4. Place instrument in original container or equally substantial heavy carton.
5. Use packing material around all sides of instrument.
6. Seal with strong tape or strapping.
7. Mark shipping container "DELICATE INSTRUMENT," "FRAGILE," etc.

3.4 Storage

If this instrument is to be stored for any extended period of time, it should be sealed in plastic and stored in a dry location. It should not be exposed to temperatures below -10°C or above +50°C. Extended exposure to temperature extremes can result in an irreversible change in resistance and would require recalibration.

Chapter 4

OPERATION

4.1 Initial Inspection and Setup

This instrument was carefully inspected before shipment. It should be in proper electrical and mechanical operating order upon receipt.

An **OPERATING GUIDE** and a **CALIBRATION CHART** are attached to the case of the instrument to provide ready reference to specifications.

4.2 Setting for Various Resistance Combinations

The HATS-Y Series Transfer Standard, may be set into any number of parallel and/or series combinations to produce different resulting net resistances.

Note the 12 switches located at the junctions of the 11 resistors as represented on the front panel. The center or **OFF** position is straight ahead with the switch set to the unconnected dot. The switch may be set, as shown, to connect to the **A** or **B** binding posts.

For resistance applications, connect to the **A** and **B** binding posts. A guard shield may be connected to the metal center binding post.

Set the switches as desired to obtain the desired resistance between the **A** and **B** binding posts. For example, set the lowest (left bank) switch to **A**; this connects the lower end of R1 to the A binding post. Then set the next the (right bank) switch to **B**; this connects the upper end of R1 to the **B** binding post. Thus, we now have R1 connected between the **A** and **B** binding posts for an effective value of 1R, where R is the step size.

For 2 R, Set the lowest switch to A as before, and set the 3rd switch (left bank) to B. Thus the unit may be set to yield resistance settings from 1R to 11R.

Note that the location of the switches on the “left bank” or the “right bank” has no significance. Any of the 12 switches may be set to either the A or B binding posts.

See Figure 4.1 for various switch configurations to get series-parallel combinations resulting in composite resistance values of R/10, 1R, and 10R. These values are very useful in calibrating resistance values having one tenth to ten times the step value. Note that the 1R value should be obtained with 9 resistors, as shown in Figure 4.1c, and not with one resistor. This offers the advantage of using the combined value of nine resistors, and allows the use of the same adjustment error

The deviations of each individual resistor from its nominal value, as well as the cumulative average deviation of the resistance string is given in a **CALIBRATION CHART** attached to the unit. Figure 2.2 shows a typical chart. Figure 4.2 may be reproduced to record later calibrations and to affix to the unit.

What is important to note is that any series, parallel, or series-parallel configuration results in the net deviation being essentially equal to the average deviation for that group of resistors regardless of how they are connected, as long as the power applied is divided equally, (or almost equally) among the resistors. This is clearly the case with the R/10 and the 10R configurations, i.e. that they have the same deviations. It is also true with the 9 resistor series-parallel configuration, since the effect of the deviation of the single missing resistor may be safely neglected. This property is very useful since it permits making accurate transfers across three decades with one single unit.

A single high accuracy, high stability standard whose value is traceable to SI may thus be transferred to other values using the HATS-Y Series in various combinations.

Example:

For example, a 10 k Ω standard may be compared with a HATS-Y unit with 100 k Ω steps connected in parallel, as described above, to provide a 10 k Ω resistance. Once a comparison is made, a net deviation of the parallel R/10 combination is obtained.

This average or net deviation remains constant for all combination, and therefore the standard is effectively "transferred" with the same deviation plus the transfer accuracy of the unit to another decade, 10R or 1 M Ω in this example. It may also be transferred to the single step R value with the series parallel combination. See Figure 4.1.

This process may be continued with another transfer standard, 10 M Ω steps in this example, which would first be configured in the R/10 mode to produce 1 M Ω to start, and then 10 M Ω and 100 M Ω with the same deviation. The transfer uncertainty as specified, must, of course, be added at each transfer.

4.2 Use as a Stand-Alone Standard

Whenever an application requires a resistance standard that has an accuracy that is met by the initial or long term accuracies of the HATS-Y Series, as specified, the HATS-Y unit may be used as a calibration source at any value desired. For example, the HATS-Y-100 k Ω step unit may be used as a calibration source with an adjustment accuracy of 10 ppm and a stability of 20 ppm/year.

4.3 Use as a Precision Voltage Divider

For voltage ratio applications, See Figure 4.3. Connect the input voltage low to bnc connector and the high to the **B** binding post. The "tap," or ratio voltage is obtained from the **A** binding post.

4.4 General Considerations for best performance

Since the HATS-Y is a precision *high* resistance unit, any electrical leakage across the terminals will affect performance, especially with higher resistance step models. It is recommended, therefore, that whenever the unit is not in use, it be kept sealed in a dry laboratory environment. It is also critical that the binding post area with the Kel-F washers be kept clean, and that there should be minimum handling to prevent any contamination from making a leakage path on the panel.

For 10 M Ω step units, allow the measurement to stabilize for as long as one or two minutes to settle to within specifications. This is needed because of the different effects of meter and bridge test currents on the very long resistance wire making up each resistor.

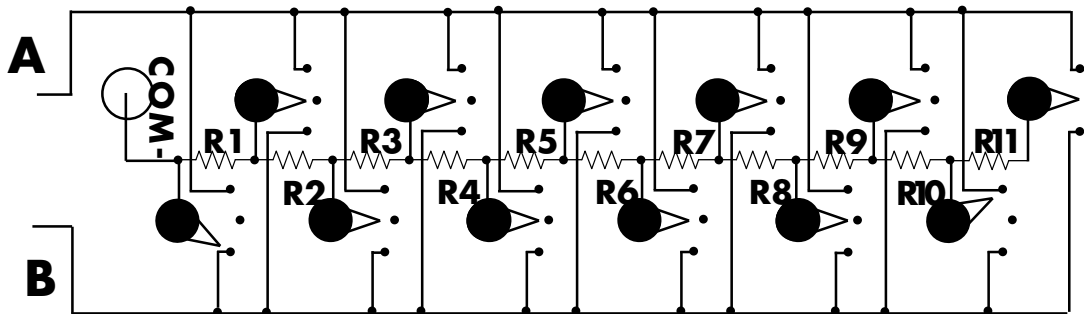

Figure 4.1a. 10 resistors in series: Resistance= 10R

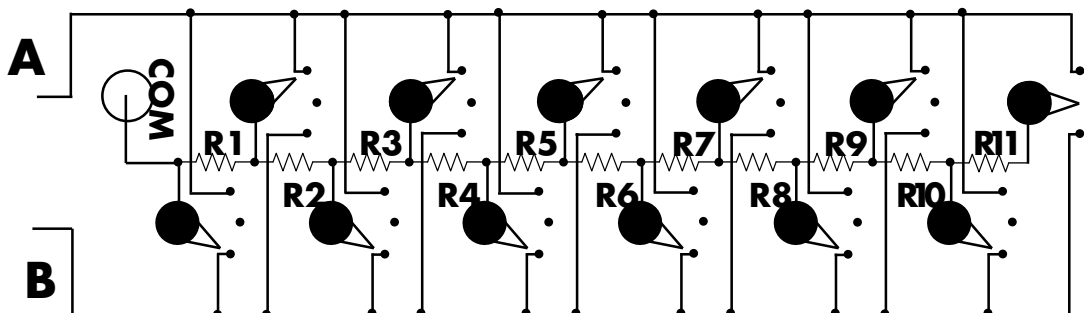

Figure 4.1b. 10 resistors in parallel: Resistance= R/10

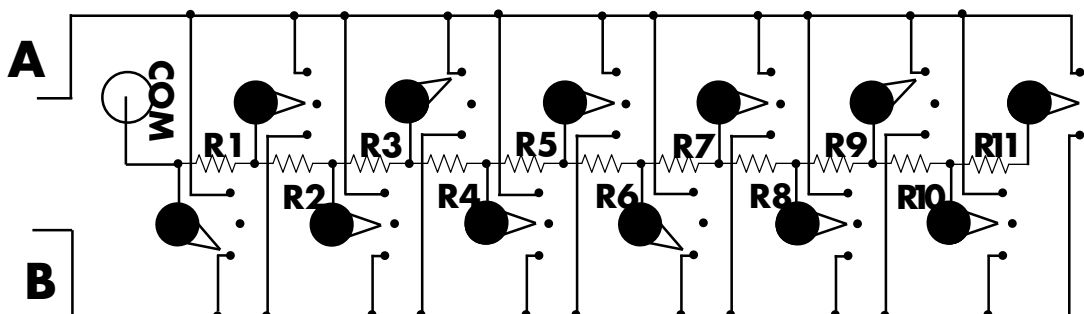

Figure 4.1c. 3 groups of 3, series-parallel: Resistance= 1 R

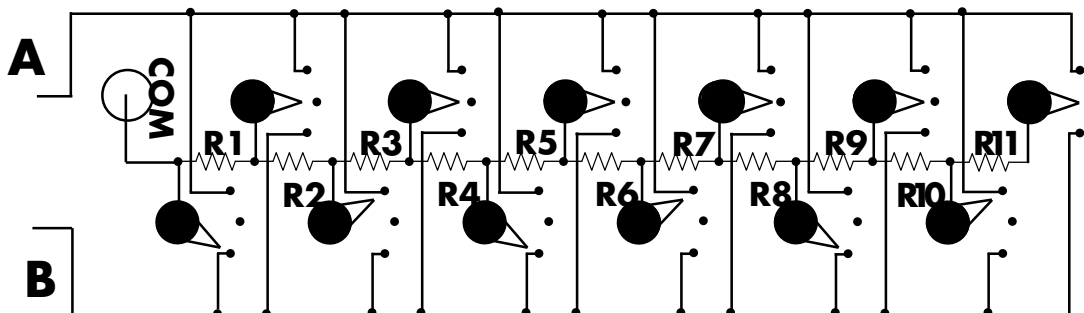

Figure 4.1d. 5 groups of 2, series-parallel: Resistance= 0.4 R

Figure 4.1 HATS-Y Resistance Combinations

CALIBRATION CHART		Individual (ppm)	Cumulative (ppm)	Temperature:
Deviations from ____ Nominal		R1		Date:
		R2		Date Due:
		R3		Model:
		R4		Serial Number:
		R5		BY:
		R6		Traceable to SI
		R7		
		R8		
		R9		
		R10		
		R11		

IET IET LABS, INC. WESTBURY
 516-334-5959 • (FAX) 516-334-5988
 www.ietlabs.com

Figure 4.2 Calibration Chart Affixed to unit

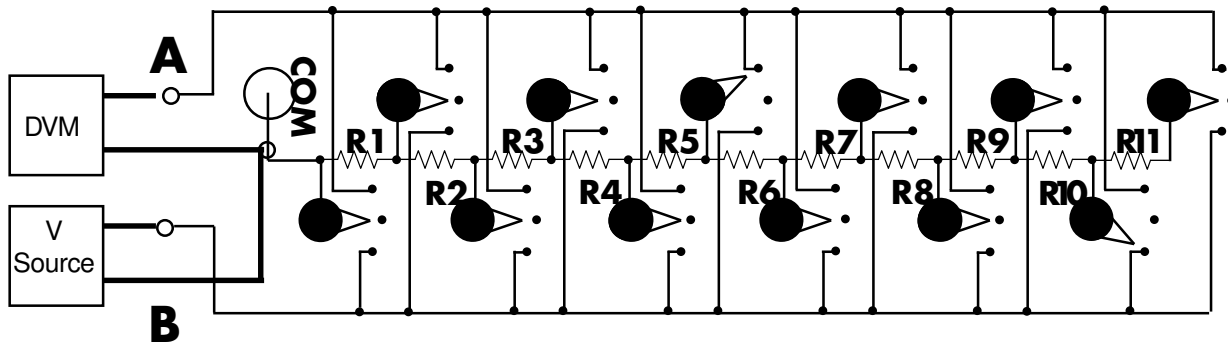

Figure 4.3 HATS-Y configured as a Precision Voltage divider
 50% Ratio in this example

Chapter 5

MAINTENANCE

5.1 Verification of Performance

5.1.1 Calibration Interval

It is recommended that the HATS-Y Series instruments should be verified for performance at a calibration interval of twelve (12) months. This procedure may be carried out by the user (if a calibration capability is available), by IET Labs, or by a certified calibration laboratory. If the user should choose to perform this procedure, then the considerations below should be observed.

Note: For HATS-Y series to be used as transfer standards only, recalibration is not *strictly* required assuming that there has been no drastic change in the deviations of any individual resistors.

5.1.2 General Considerations

It is important, whenever calibrating or certifying the HATS-Y Series Transfer Standards, to be very aware of the capabilities and limitations of the test instruments used. A resistance standard and a DMM with sufficient capability is recommended.

It is important to allow both the testing instrument and the HATS-Y standard to stabilize for a number of hours at laboratory conditions of temperature and humidity. There should be no temperature gradients across the unit under test.

Proper metrology practices should be followed in performing this verification or calibration. Special care should be exercised for the high resistance values

5.1.3 Verification Procedure

Determine the allowable upper and lower limits for each resistance step. In particular these may be the specified long term accuracy limits.

Perform measurements under stabilized temperatures and with the HATS-Y instrument case connected to the appropriate measuring instrument guard point.

Confirm that the resistances fall within these limits.

If desired, the new verified values may be entered on a facsimile of the calibration chart in Figure 4.2 and affixed in place of or on top of the existing calibration chart.

If any resistances fall outside these limits, they may be calibrated as described below.

5.2 Calibration

If any individual resistance requires calibration, the associated resistor network may be trimmed by adjusting the potentiometer for that resistance.

Loosen the four captive screws at the corners of the HATS-Y unit and carefully lift the unit out of the enclosure. Set it on a teflon or styrofoam insulating pad.

Nothing should be touched with bare hands. If it should become necessary to handle any internal component, gloves should be worn. This procedure should be performed in an environment as free as possible from electrical noise due to the high impedance of these instruments. If this is not possible, or for best results, the effects of such noise may be minimized by the use of a Faraday cage and/or a ground plane.

HATS-Y Series

Connect the DMM across the A and B binding posts with any guard shield connected to the center metal binding post. Set the switches as described above to access each resistor. Locate the trimming potentiometer for each resistor; unlock the potentiometer and adjust to trim the step under test. After making the adjustment, move away from the unit and allow the measurement to settle to its final reading. This procedure can be time consuming, requiring several minutes for each step.

After Adjustment of all required resistances in the unit, return it to its enclosure and fasten with the four retaining screws. Then recheck all 11 values, and repeat the adjustment procedure if necessary